



Inorax-AL Network Rack Cabinet

Inorax-AL network rack cabinet system offers the best solution for IT and Telecom applications in dense and complex cabling environments. A wide range of cable management accessories is available to ensure perfect management of copper & fiber cables and 19" equipment. Vertical 19" mounting rails can be adjusted freely through the depth, which simplifies mounting of any device and configuration of connecting cables. Black tinted left and right sections on the front glass door hides the excess cables from the view of the user and gives an aesthetic look to the rack. Flat-pack option enables savings up to 60% in the transport cost and warehouse space.

Technical Features

Material	Frame ; Anodized aluminum extrusion profiles Other parts : 1,2 and 2 mm steel
Color	RAL 7035 or RAL 9005
Compliance	RoHS, UL Certified
Packaging	Assembled or unassembled
Maximum Static Load	Up to 2000 kg.
Finish	Doors, side panels, top covers: Electrostatic Powder Paint 19" mounting rails: Zinc-plated

Standard Configuration:

- Front door with safety glass
- Solid Side Panels with cylindrical locks and latches
- Solid Rear Panel with cylindrical locks
- Internal top sheet with 3 cable entries for 800 width, 1 cable entry for 600 width racks and fan cut-outs
- 2 Pairs of depth adjustable heavy duty 19" Mounting Rails
- 2 Pairs of Adjustable Feet
- Front Door with swing-handle single point lock
- Bottom sheet is not included



CERTIFIED

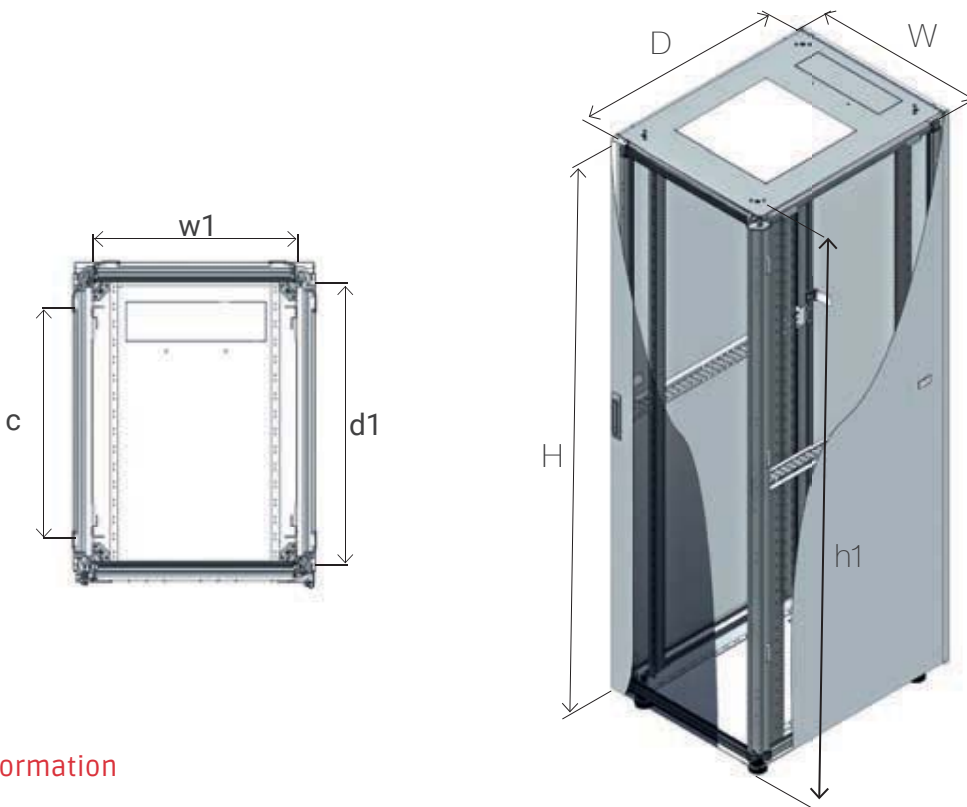

Order Information

Height U	Outer width (w) mm	Outer Depth (D) mm	Outer Height (H) mm	Inner Width (w1) mm	Inner Depth (d1) mm	Inner Height (h1) mm	19" Rails Adjustable Depth Range (c)	Weight kg	Part No
26U	600	600	1322	503	550	1187	129-429	57	CPN-X-2666A
26U	600	800	1322	503	750	1187	129-629	74	CPN-X-2668A
26U	800	800	1322	703	750	1187	129-629	84	CPN-X-2688A
32U	600	600	1589	503	550	1454	129-429	67	CPN-X-3266A
32U	600	800	1589	503	750	1454	129-629	83	CPN-X-3268A
32U	800	800	1589	703	750	1454	129-629	95	CPN-X-3288A
36U	600	600	1767	503	550	1632	129-429	74	CPN-X-3666A
36U	600	800	1767	503	750	1632	129-629	88	CPN-X-3668A
36U	800	800	1767	703	750	1632	129-629	103	CPN-X-3688A
39U	800	800	1900	703	750	1765	129-629	108	CPN-X-3988A
42U	600	600	2033	503	550	1898	129-429	85	CPN-X-4266A
42U	600	800	2033	503	750	1898	129-629	97	CPN-X-4268A
42U	600	1000	2033	503	950	1898	129-829	103	CPN-X-4260A
42U	800	800	2033	703	750	1898	129-629	114	CPN-X-4288A
42U	800	1000	2033	703	950	1898	129-829	119	CPN-X-4280A
47U	600	600	2255	503	550	2120	129-429	93	CPN-X-4766A
47U	600	800	2255	503	750	2120	129-629	104	CPN-X-4768A
47U	600	1000	2255	503	950	2120	129-829	120	CPN-X-4760A
47U	800	800	2255	703	750	2120	129-629	124	CPN-X-4788A
47U	800	1000	2255	703	950	2120	129-829	130	CPN-X-4780A

X (Color code): 7:RAL 7035 Light Grey, 9:RAL 9005 Black

Components of Inorax-AL

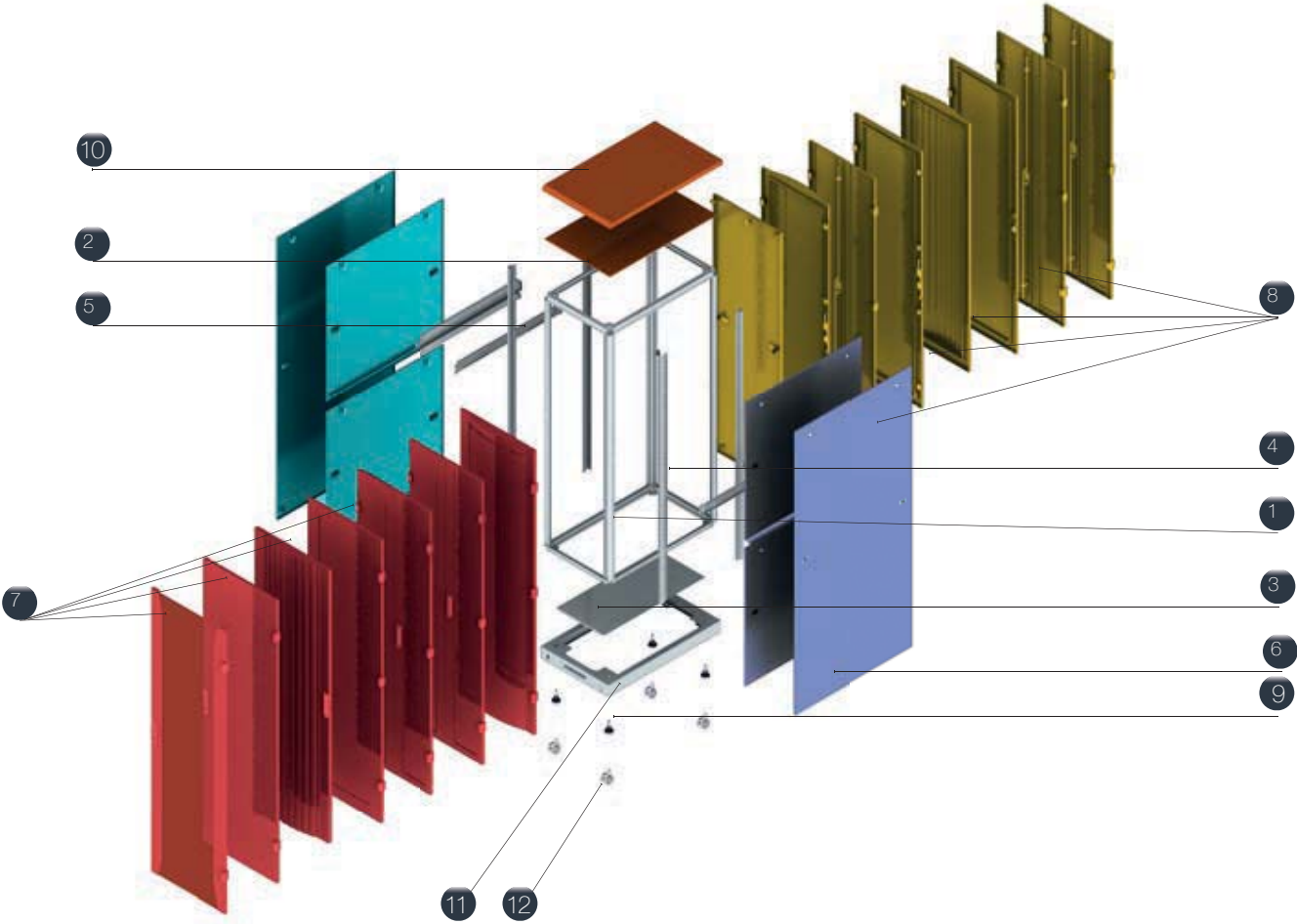

- 1- Aluminum Frame
- 2 - Top Sheet
- 3 - Bottom Sheet
- 4 - 19" Mounting Rails
- 5 - Side Support Rail
- 6 - Side Panel Options
- 7 - Front Door Options
- 8 - Rear Door Options

- 9 - Adjustable Feet
- 10 - External Top Cover
- 11 - Plinth
- 12 - Castor



Page : 88 - 89



Page : 90



Page : 91



Page : 92



Page : 93



Page : 94 - 95

Components of Inorax-AL Frame

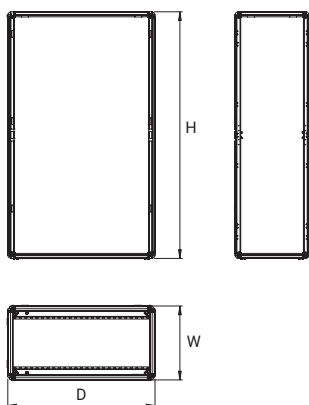

Material	Anodized Aluminum Extrusion	Maximum Static Load	2000 kg
Finish	Anodic Oxidation (Eloxal)		

Height U	H (mm)	W (mm)	D (mm)	Weight kg	Part No
26U	1308,8	600	600	16,00	CPZ-X-26660-0100
26U	1308,8	600	800	17,28	CPZ-X-26680-0100
26U	1308,8	600	1000	18,66	CPZ-X-26600-0100
26U	1308,8	800	800	26,22	CPZ-X-26880-0100
32U	1575,5	600	600	16,40	CPZ-X-32660-0100
32U	1575,5	600	800	17,71	CPZ-X-32680-0100
32U	1575,5	800	800	26,60	CPZ-X-32880-0100
36U	1753,3	600	600	16,65	CPZ-X-36660-0100
36U	1753,3	600	800	17,98	CPZ-X-36680-0100
36U	1753,3	600	1000	19,42	CPZ-X-36600-0100
36U	1753,3	600	1200	20,97	CPZ-X-36620-0100
36U	1753,3	800	800	26,84	CPZ-X-36880-0100
39U	1886,6	800	800	26,96	CPZ-X-39880-0100
39U	1886,6	800	1000	29,93	CPZ-X-39800-0100
42U	2020	600	600	17,03	CPZ-X-42660-0100
42U	2020	600	800	18,39	CPZ-X-42680-0100
42U	2020	600	1000	19,86	CPZ-X-42600-0100
42U	2020	600	1070	20,65	CPZ-X-42610-0100
42U	2020	600	1200	21,45	CPZ-X-42620-0100
42U	2020	800	800	27,15	CPZ-X-42880-0100
42U	2020	800	1000	30,14	CPZ-X-42800-0100
42U	2020	800	1070	31,79	CPZ-X-42810-0100
42U	2020	800	1200	33,45	CPZ-X-42820-0100
47U	2242,25	600	600	17,33	CPZ-X-47660-0100
47U	2242,25	600	800	18,72	CPZ-X-47680-0100
47U	2242,25	600	1000	20,21	CPZ-X-47600-0100
47U	2242,25	600	1200	21,83	CPZ-X-47620-0100
47U	2242,25	800	800	27,46	CPZ-X-47880-0100
47U	2242,25	800	1000	30,48	CPZ-X-47800-0100
47U	2242,25	800	1200	33,83	CPZ-X-47820-0100

Top Sheet

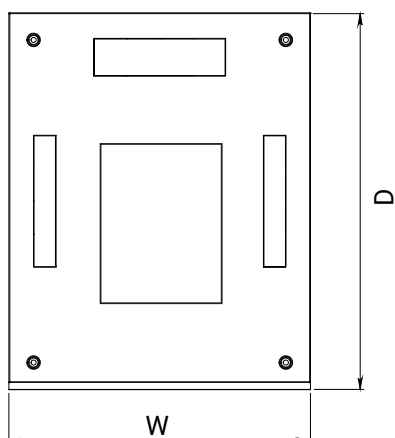

Material	1.2 mm Steel	Color	RAL 7035 and RAL 9005
Finish	Electrostatic Powder Paint		

W (mm)	D (mm)	H (mm)	Weight kg	Part No
600	600	7	3,24	CPZ-X-YY660-0402
600	800	7	4,34	CPZ-X-YY680-0402
600	1000	7	5,82	CPZ-X-YY600-0402
600	1070	7	6,25	CPZ-X-YY670-0402
600	1200	7	7,80	CPZ-X-YY620-0402
800	800	7	5,76	CPZ-X-YY880-0402
800	1000	7	5,92	CPZ-X-YY800-0402
800	1070	7	6,39	CPZ-X-YY870-0402
800	1200	7	6,96	CPZ-X-YY820-0402

X (Color code): 7:RAL 7035 Light Grey, 9:RAL 9005 Black

Material	1.2 mm Steel	Color	RAL 7035 and RAL 9005
Finish	Electrostatic Powder Paint		

W (mm)	D (mm)	H (mm)	Weight kg	Part No
600	600	30	4,49	CPZ-X-YY660-0404
600	800	30	5,76	CPZ-X-YY680-0404
600	1000	30	7,05	CPZ-X-YY600-0404
600	1070	30	7,82	CPZ-X-YY670-0404
600	1200	30	8,6	CPZ-X-YY620-0404
800	800	30	7,11	CPZ-X-YY880-0404
800	1000	30	9,12	CPZ-X-YY800-0404
800	1070	30	10,12	CPZ-X-YY870-0404
800	1200	30	11,12	CPZ-X-YY820-0404

External Top Cover

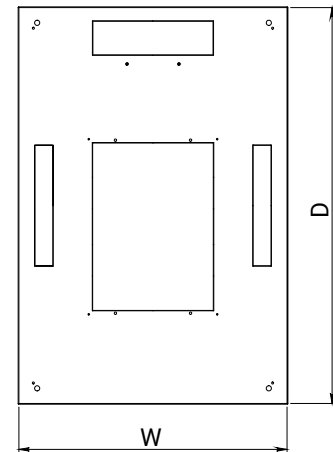

Material	2 mm Steel	Finish	Zinc Plated
-----------------	------------	---------------	-------------

Cabinet W (mm)	Cabinet D (mm)	Weight kg	Part No
600	600	0,75	CPZ-0-YY660-0700
600	800	0,80	CPZ-0-YY680-0700
600	1000	0,85	CPZ-0-YY600-0700
600	1070	0,87	CPZ-0-YY670-0700
600	1200	0,90	CPZ-0-YY620-0700
800	800	0,85	CPZ-0-YY880-0700
800	1000	0,92	CPZ-0-YY800-0700
800	1070	0,97	CPZ-0-YY870-0700
800	1200	1,02	CPZ-0-YY820-0700

Side Support Rails

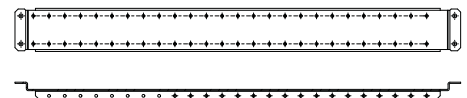

X (Color code): 7:RAL 7035 Light Grey, 9:RAL 9005 Black

Bottom Sheet

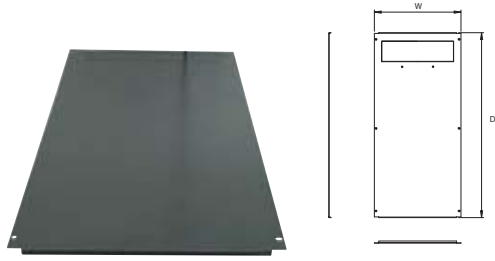

Material	1.2 mm Steel	Finish	Electrostatic Powder Paint	
Color	RAL 7035 (Light Grey) and RAL 9005 (Black)			
W (mm)	D (mm)	H (mm)	Weight kg	Part No
600	600	5	1,84	CPZ-X-YY660-0403
600	800	5	2,45	CPZ-X-YY680-0403
600	1000	5	3,06	CPZ-X-YY600-0403
600	1070	5	3,37	CPZ-X-YY670-0403
600	1200	5	3,67	CPZ-X-YY620-0403
800	800	5	2,45	CPZ-X-YY880-0403
800	1000	5	3,06	CPZ-X-YY800-0403
800	1070	5	3,37	CPZ-X-YY870-0403
800	1200	5	3,67	CPZ-X-YY820-0403

19" Mounting Rails

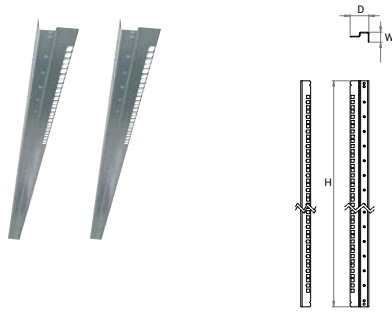

Material	2 mm Steel	Finish	Zinc-Plated		
H (U)	W (mm)	D (mm)	H (mm)	Weight kg	Part No
26U	33	52	1198	1,52	CPZ-0-26YY0-0600
32U	33	52	1464	1,85	CPZ-0-32YY0-0600
36U	33	52	1642	2,08	CPZ-0-36YY0-0600
39U	33	52	1776	2,25	CPZ-0-39YY0-0600
42U	33	52	1909	2,42	CPZ-0-42YY0-0600
47U	33	52	2131	2,7	CPZ-0-47YY0-0600

Side Panel

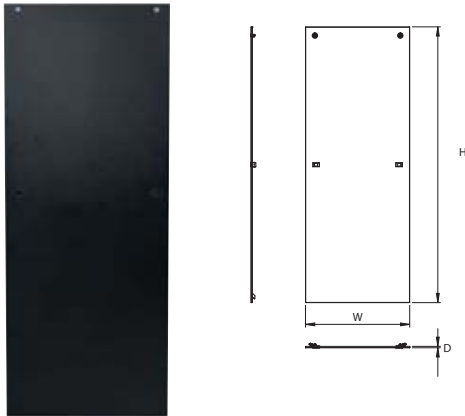

Material	1,2 mm Steel	Color	RAL 7035 and RAL 9005		
Finish	Electrostatic Powder Paint				
H (U)	W (mm)	D (mm)	H (mm)	Weight kg	Part No
26U	600	10	1264	7,11	CPZ-X-26Y60-0501
26U	800	10	1264	9,46	CPZ-X-26Y80-0501
26U	1000	10	1264	12,58	CPZ-X-26Y00-0501
32U	600	10	1531	8,53	CPZ-X-32Y60-0501
32U	800	10	1531	11,35	CPZ-X-32Y80-0501
36U	600	10	1709	9,49	CPZ-X-36Y60-0501
36U	800	10	1709	12,62	CPZ-X-36Y80-0501
39U	800	10	1842	13,57	CPZ-X-39Y80-0501
42U	600	10	1975	10,93	CPZ-X-42Y60-0501
42U	800	10	1975	14,54	CPZ-X-42Y80-0501
47U	600	10	2198	12,13	CPZ-X-47Y60-0501
47U	800	10	2198	16,13	CPZ-X-47Y80-0501

High Perforation Rated Curved Door for Colocation Cabinets

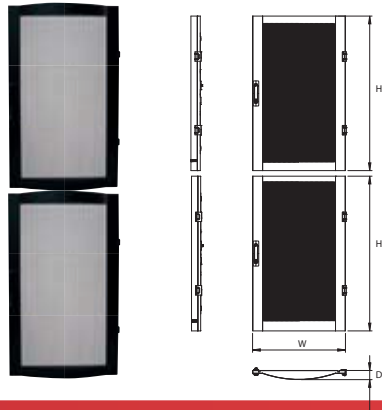

Material	1.2 mm Steel	Finish	Electrostatic Powder Paint		
Perforation Rate	82%	Color	RAL 7035 and RAL 9005		
H (U)	W (mm)	D (mm)	H (mm)	Weight kg	Part No
21U+21U	600	57	1975	10,20	CPZ-X-426Y0-0912
21U+21U	800	76	1975	11,32	CPZ-X-428Y0-0912

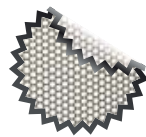

Formed Pattern Perforation with 80%

X (Color code): 7:RAL 7035 Light Grey, 9:RAL 9005 Black

Split Side Panel

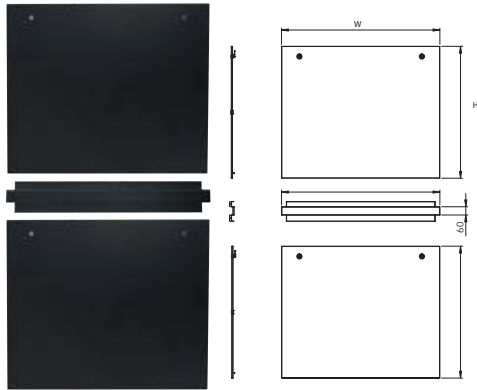

Material	1.2 mm Steel	Finish	Electrostatic Powder Paint		
Color	RAL 7035 (Light Grey) and RAL 9005 (Black)				
H (U)	W (mm)	D (mm)	H (mm)	Weight kg	Part No
36U	1000	10	1709	16,79	CPZ-X-36Y00-0503
36U	1200	10	1709	22,33	CPZ-X-36Y20-0503
39U	1000	10	1842	18,06	CPZ-X-39Y00-0503
42U	1000	10	1975	19,33	CPZ-X-42Y00-0503
42U	1070	10	1975	23,67	CPZ-X-42Y70-0503
42U	1200	10	1975	25,71	CPZ-X-42Y20-0503
47U	1000	10	2198	21,46	CPZ-X-47Y00-0503
47U	1070	10	2198	25,00	CPZ-X-47Y70-0503
47U	1200	10	2198	28,54	CPZ-X-47Y20-0503

Rear Metal Solid Panel

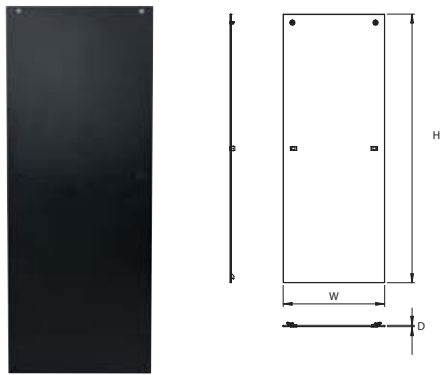

Material	1.2 mm Steel	Finish	Electrostatic Powder Paint		
Color	RAL 7035 (Light Grey) and RAL 9005 (Black)				
H (U)	W (mm)	D (mm)	H (mm)	Weight kg	Part No
26U	600	23	1264	8,40	CPZ-X-266Y0-0901
26U	800	23	1264	11,59	CPZ-X-268Y0-0901
32U	600	23	1531	10,09	CPZ-X-326Y0-0901
32U	800	23	1531	13,92	CPZ-X-328Y0-0901
36U	600	23	1709	11,21	CPZ-X-366Y0-0901
36U	800	23	1709	15,47	CPZ-X-368Y0-0901
39U	800	23	1842	16,62	CPZ-X-398Y0-0901
42U	600	23	1975	12,89	CPZ-X-426Y0-0901
42U	800	23	1975	17,79	CPZ-X-428Y0-0901
47U	600	23	2198	14,29	CPZ-X-476Y0-0901
47U	800	23	2198	19,72	CPZ-X-478Y0-0901

Metal Solid Door

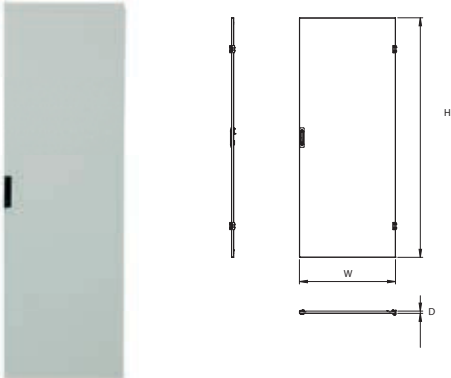

Material	1.2 mm Steel	Finish	Electrostatic Powder Paint		
Color	RAL 7035 (Light Grey) and RAL 9005 (Black)				
H (U)	W (mm)	D (mm)	H (mm)	Weight kg	Part No
26U	600	10	1264	11,08	CPZ-X-266Y0-0902
26U	800	10	1264	13,74	CPZ-X-268Y0-0902
32U	600	10	1531	13,15	CPZ-X-326Y0-0902
32U	800	10	1531	16,31	CPZ-X-328Y0-0902
36U	600	10	1709	14,50	CPZ-X-366Y0-0902
36U	800	10	1709	17,98	CPZ-X-368Y0-0902
39U	800	10	1842	19,24	CPZ-X-398Y0-0902
42U	600	10	1975	16,54	CPZ-X-426Y0-0902
42U	800	10	1975	20,51	CPZ-X-428Y0-0902
47U	600	10	2198	18,24	CPZ-X-476Y0-0902
47U	800	10	2198	22,62	CPZ-X-478Y0-0902

Glass Door Supported By Metal Brackets

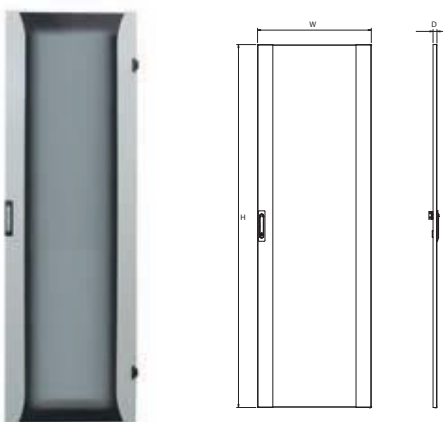

Material	1.2 mm Steel, 4 mm Tempered Glass, tinted on left and right sides				
Finish	Electrostatic Powder Paint				
Color	RAL 7035 (Light Grey) and RAL 9005 (Black)				
H (U)	W (mm)	D (mm)	H (mm)	Weight kg	Part No
26U	600	19	1264	9,41	CPZ-X-266Y0-0903
26U	800	19	1264	11,86	CPZ-X-268Y0-0903
32U	600	19	1531	11,29	CPZ-X-326Y0-0903
32U	800	19	1531	14,23	CPZ-X-328Y0-0903
36U	600	19	1709	12,55	CPZ-X-366Y0-0903
36U	800	19	1709	15,81	CPZ-X-368Y0-0903
39U	800	19	1842	17,00	CPZ-X-398Y0-0903
42U	600	19	1975	14,43	CPZ-X-426Y0-0903
42U	800	19	1975	18,18	CPZ-X-428Y0-0903
47U	600	19	2198	16,00	CPZ-X-476Y0-0903
47U	800	19	2198	20,16	CPZ-X-478Y0-0903

X : Color code = 7: RAL 7035 (Grey); 9: RAL 9005 (Black)

Perforated Curved Door

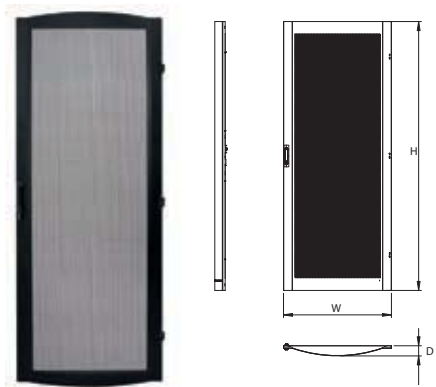

Material	1.2 mm Steel	Finish	Electrostatic Powder Paint		
Perforation Rate	67%	Color	RAL 7035 and RAL 9005		
H (U)	W (mm)	D (mm)	H (mm)	Weight kg	Part No
26U	600	57	1264	9,41	CPZ-X-266Y0-0905
36U	600	57	1709	12,55	CPZ-X-366Y0-0905
39U	800	76	1842	17,00	CPZ-X-398Y0-0905
42U	600	57	1975	14,43	CPZ-X-426Y0-0905
42U	800	76	1975	18,18	CPZ-X-428Y0-0905
47U	600	57	2198	16,00	CPZ-X-476Y0-0905
47U	800	76	2198	20,16	CPZ-X-478Y0-0905

Perforated Flat Door

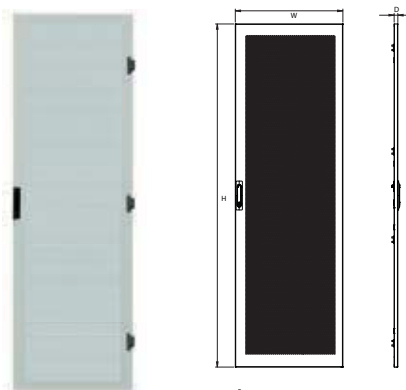

Material	1.2 mm Steel	Finish	Electrostatic Powder Paint		
Perforation Rate	65%	Color	RAL 7035 and RAL 9005		
H (U)	W (mm)	D (mm)	H (mm)	Weight kg	Part No
26U	600	19	1264	8,21	CPZ-X-266Y0-0904
36U	600	19	1709	11,35	CPZ-X-366Y0-0904
39U	800	19	1842	15,50	CPZ-X-398Y0-0904
42U	600	19	1975	12,23	CPZ-X-426Y0-0904
42U	800	19	1975	16,08	CPZ-X-428Y0-0904
47U	600	19	2198	14,90	CPZ-X-476Y0-0904
47U	800	19	2198	18,86	CPZ-X-478Y0-0904

Perforated Double Flat Door

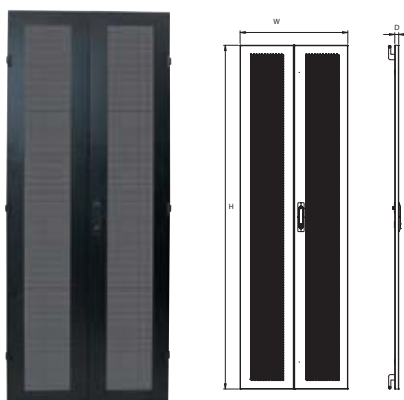

Material	1.2 mm Steel	Finish	Electrostatic Powder Paint		
Perforation Rate	65%	Color	RAL 7035 and RAL 9005		
H (U)	W (mm)	D (mm)	H (mm)	Weight kg	Part No
26U	600	19	1264	8,38	CPZ-X-266Y0-0908
36U	600	19	1709	10,14	CPZ-X-366Y0-0908
39U	800	19	1842	13,53	CPZ-X-398Y0-0908
42U	600	19	1975	11,45	CPZ-X-426Y0-0908
42U	800	19	1975	14,40	CPZ-X-428Y0-0908
47U	600	19	2198	12,57	CPZ-X-476Y0-0908
47U	800	19	2198	15,74	CPZ-X-478Y0-0908

Double Glass Door



Material	1.2 mm Steel, 4 mm Tempered Glass				
Finish	Electrostatic Powder Paint				
Color	RAL 7035 (Light Grey) and RAL 9005 (Black)				
H (U)	W (mm)	D (mm)	H (mm)	Weight kg	Part No
42U	800	19	1975	20,66	CPZ-X-428Y0-0907
47U	800	19	2198	22,70	CPZ-X-478Y0-0907

X : Color code = 7: RAL 7035 (Grey); 9: RAL 9005 (Black)

Double Metal Solid Door

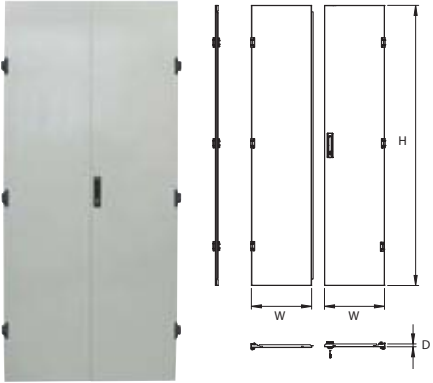

Material	1.2 mm Steel	Finish	Electrostatic Powder Paint		
Color	RAL 7035 and RAL 9005				
H (U)	W (mm)	D (mm)	H (mm)	Weight kg	Part No
42U	800	19	1975	20,81	CPZ-X-428Y0-0906
47U	800	19	2198	23,12	CPZ-X-478Y0-0906

High Perforation Rated Flat Door

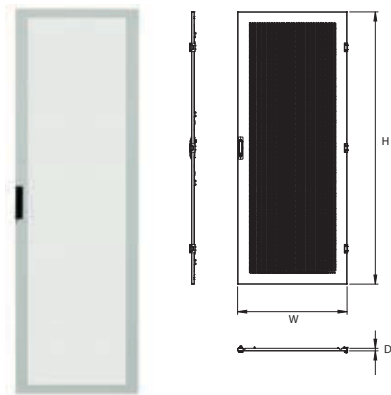

Material	1.2 mm Steel	Finish	Electrostatic Powder Paint		
Perforation Rate	80%	Color	RAL 7035 and RAL 9005		
H (U)	W (mm)	D (mm)	H (mm)	Weight kg	Part No
26U	600	19	1264	7,91	CPZ-X-266Y0-0909
42U	600	19	1975	11,93	CPZ-X-426Y0-0909
42U	800	19	1975	15,78	CPZ-X-428Y0-0909
47U	600	19	2198	14,60	CPZ-X-476Y0-0909
47U	800	19	2198	18,56	CPZ-X-478Y0-0909

High Perforation Rated Curved Door

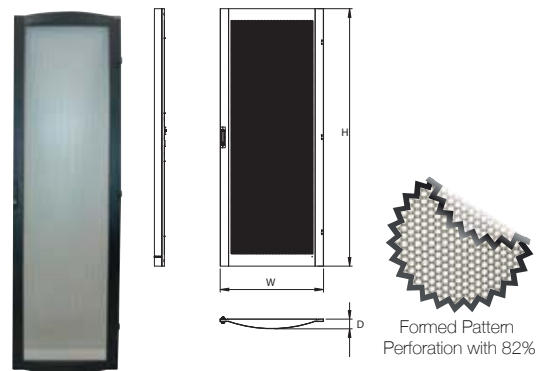

Material	1.2 mm Steel	Finish	Electrostatic Powder Paint		
Perforation Rate	82%	Color	RAL 7035 and RAL 9005		
H (U)	W (mm)	D (mm)	H (mm)	Weight kg	Part No
26U	600	57	1264	9,10	CPZ-X-266Y0-0910
42U	600	57	1975	14,13	CPZ-X-426Y0-0910
42U	800	76	1975	17,88	CPZ-X-428Y0-0910
47U	600	57	2198	15,70	CPZ-X-476Y0-0910
47U	800	76	2198	19,86	CPZ-X-478Y0-0910

High Perforation Rated Double Flat Door

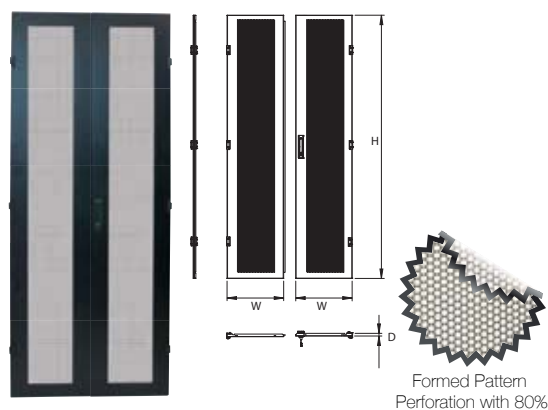

Material	1.2 mm Steel	Finish	Electrostatic Powder Paint		
Perforation Rate	80%	Color	RAL 7035 and RAL 9005		
H (U)	W (mm)	D (mm)	H (mm)	Weight kg	Part No
26U	600	19	1264	8,08	CPZ-X-266Y0-0911
36U	600	19	1709	9,84	CPZ-X-366Y0-0911
39U	800	19	1842	13,23	CPZ-X-398Y0-0911
42U	600	19	1975	11,15	CPZ-X-426Y0-0911
42U	800	19	1975	14,10	CPZ-X-428Y0-0911
47U	600	19	2198	12,27	CPZ-X-476Y0-0911
47U	800	19	2198	15,44	CPZ-X-478Y0-0911

X : Color code = 7: RAL 7035 (Grey); 9: RAL 9005 (Black)

Adjustable Feet

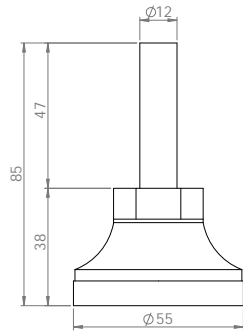

Material	Steel and Plastic ABS	Finish	Zinc Plated
Packaging	4 pieces in a box		
Maximum Static Load	Set Weight kg	Part No	
600 kg / piece	0.35	CCA-0-7014	

Multi Point Lock for Double Doors



Material	Polyamide, Steel
Packaging	1 piece in a box
Part No	CPZ-0-YYYY0-1005

Four Point Lock for Single Perforated Door



Material	Polyamide, Steel
Packaging	1 piece in a box
Part No	CPZ-0-YYYY0-1004

Three Point Lock for Single Perforated Door



Material	Polyamide, Steel
Packaging	1 piece in a box
Part No	CPZ-0-YYYY0-1006